

TeleCrawler22S

MAX. KORBTAGLAST 230 KG
(2 Personen 80x2=160 kg + Werkzeugkasten 70 kg)

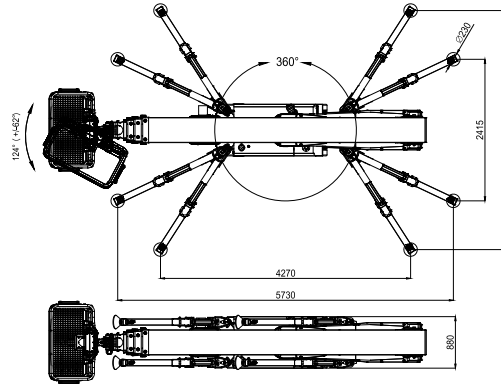
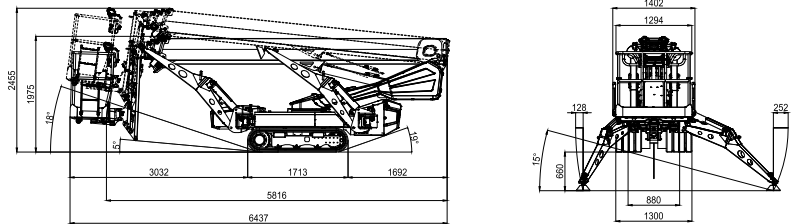
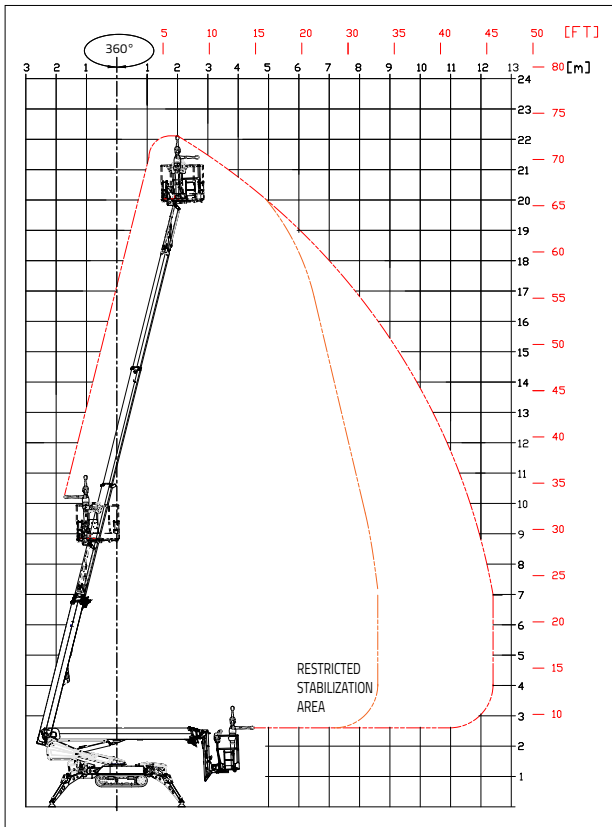

TOTALE ABSTÜTZFLÄCHE

PARTIELLE ABSTÜTZFLÄCHE

REDUZIERTE ABSTÜTZFLÄCHE

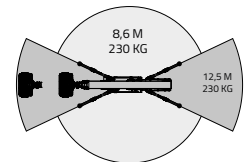
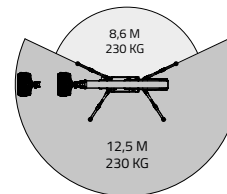
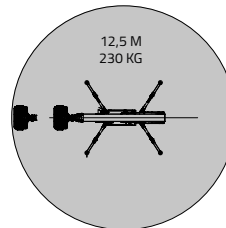

22 m



1480x610xh.1100 mm
DSE (Dual Side Entry)



IIS –Abstütz- und Einfahrtomatik
serienmässig



12,4 m



124° (+/-62°)



Kabelfernbedienung



6,44 m



880 - 1300 mm



GPRS-GPS



5,82 m



Totale Abstützfläche 4080 x 4270 mm
Reduzierte Abstützfläche 2415 x 5730 mm
Partielle Abstützfläche 3250 x (4270/5730) mm



R.A.H.M.



1,98 m



Elektromotor mit Lithium-Batterien
6,1 kWh



Bi-energy (Dual-Antrieb Diesel und
Lithium-Ionen-Akku) - 3,5kW 48V

TeleCrawler22S



DIESELMOTOR

HerstellerKUBOTA
 ModellZ602
 Zylinder und Hubraum Zweizylinder 599 cm³
 Max. Bruttoleistung
 14,5 PS - 10,8kW @ 3200 rpm
 Elektrischer Anlasser 12 volt

ELEKTROMOTOR MIT LITHIUM-BATTERIEN

Lithium Akkupack6,1 kWh
 Batterielader an Bord
 220V o 110V +-30V 50-60 Hz
 Arbeitsautonomie 4-5 h
 Ladezeit bei komplett leeren Batterien
 4 h (Schätzwert)
 Ladezeit bis 80% bei komplett leeren Batterien
 2 h (Schätzwert)

ELEKTROMOTOR

Standard 230V / 50 Hz - 2,2 kW
 Optional 110V / 50 Hz - 2,2 kW

RAUPENFAHRWERK

Kettenspanner mit Schmierfett
 Stützrollen pro Seite 3 + Schlitten

MASCHINENGEWICHT Dieselmotor 3350 kg
 MASCHINENGEWICHT lithium 3300 kg
 MASCHINENGEWICHT bi-energy 3350 kg

MAX. WINDGESCHWINDIGKEIT 12,5 m/s